



INSTALLATION AND OPERATING INSTRUCTIONS

REFRIGERATOR FOR LP-GAS AND ELECTRIC OPERATION

RM2351

AMERICANA



Contents:

	Page
Installation	4
Operating Instructions	8
Maintenance & Service	12

FOR YOUR SAFETY

If you smell gas:

1. Open windows.
2. Don't touch electrical switches.
3. Extinguish any open flame.
4. Immediately call your gas supplier.

Pour votre sécurité

Si vous sentez une odeur de gaz:

1. Ouvrez les fenêtres.
2. Ne touchez à aucun interrupteur.
3. Éteignez toute flamme nue.
4. Avertissez immédiatement votre fournisseur de gaz.

FOR YOUR SAFETY

Do not store or use gasoline or other flammable vapors and liquids in the vicinity of this or any other appliance.

Pour votre sécurité

Ne pas entreposer ni utiliser de l'essence ni d'autres vapeurs ou liquides inflammables à proximité de cet appareil ou de tout autre appareil.

WARNING: Improper installation, adjustment, alteration, service or maintenance can cause injury or property damage. Refer to this manual. For assistance or additional information consult a qualified installer, service agency or the gas supplier.

Avertissement: Une installation, un réglage, une modification, une réparation ou un entretien non conforme aux normes peut entraîner des blessures ou des dommages matériels. Lisez attentivement le mode d'emploi fourni avec l'appareil. Pour obtenir de l'aide ou des renseignements supplémentaires, consultez un installateur ou un service d'entretien qualifié ou le fournisseur de gaz.



USA
Service Office
Dometic Corporation
2320 Industrial Parkway
Elkhart, IN 46515
Phone: 574-294-2511

Corporate Office
2320 Industrial Parkway Elkhart, IN 46515

For Service Center Assistance
Call: 800-544-4881

CANADA
Dometic Distribution Inc.
866 Langs Drive
Cambridge, Ontario
N3H 2N7 Canada
Phone: 519-653-4390

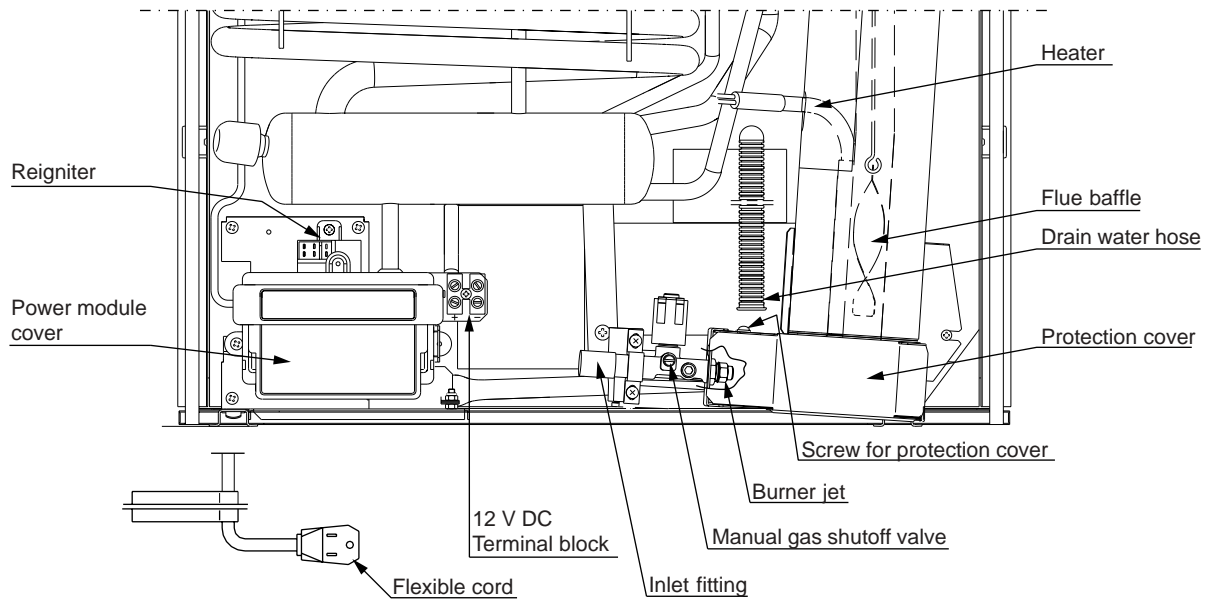

FIG. 1

Refrigerator control panel

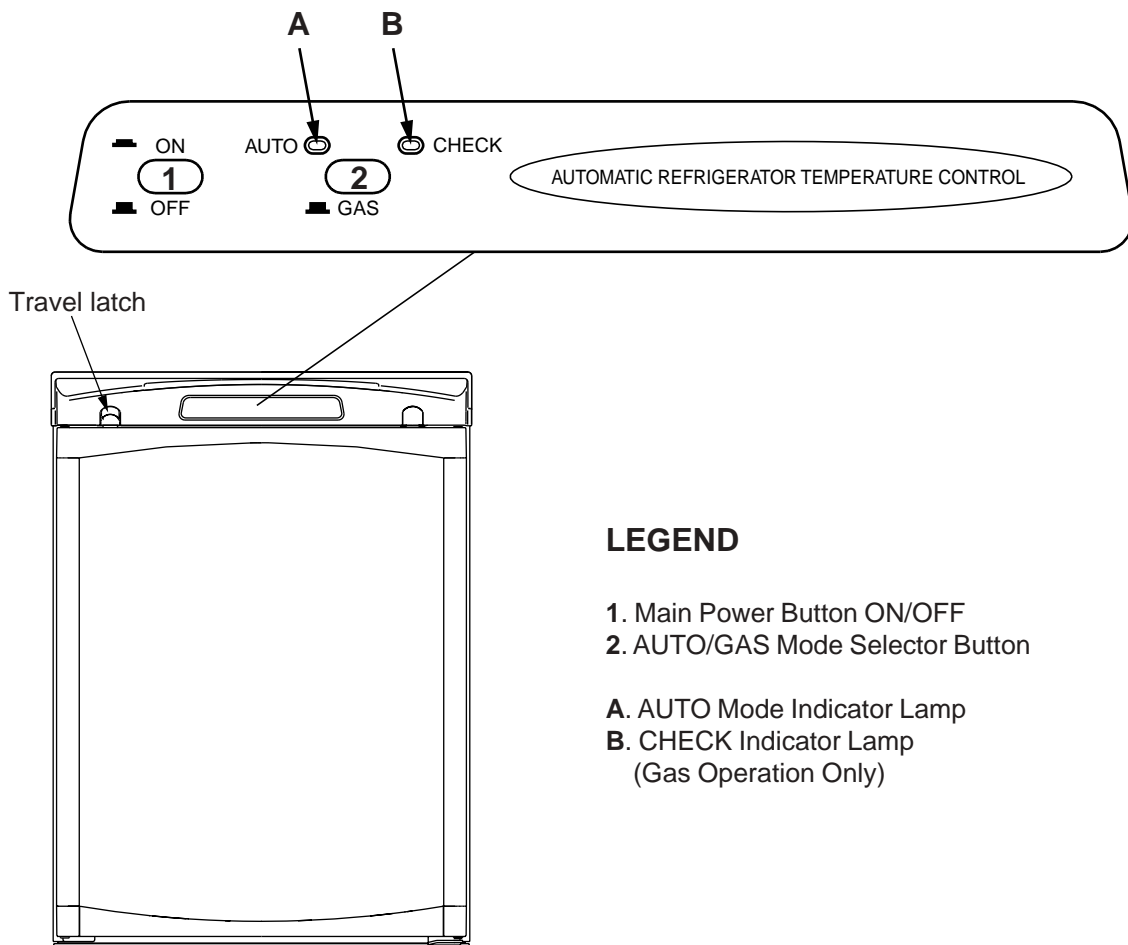

FIG. 2

INSTALLATION

GENERAL INSTRUCTION

This appliance is designed for storage of foods and storage of frozen foods and making ice.

This appliance is certified under the latest edition of ANSI Z21.19•CSA 1.4 Refrigerators using gas fuel.

The installation must conform with local codes, or in absence of local codes, the following standards as applicable.

In the U.S. the installation must conform with:

1. National Fuel Gas Code, ANSI Z223.1/NFPA 54 (latest edition).
2. Recreational Vehicles Code, ANSI A119.2 (latest edition)
3. Manufactured Home Construction and Safety Standard, Title 24 CFR, Part 3280.

If an external electrical source is utilized, the refrigerator, when installed, must be electrically grounded in accordance with local codes or, in the absence of local codes, the National Electrical Code, ANSI/NFPA 70 - (latest edition).

In CANADA, the installation must conform with:

1. Natural Gas and Propane Installation Code, CSA B149.1
2. CSA Z240 RV Series, Recreational Vehicles.
3. Current CSA Z240.4, Gas-equipped Recreational Vehicles and Mobile Housing.

If an external electrical source is utilized, the refrigerator, when installed, must be electrically grounded in accordance with local codes or, in the absence of local codes, the Canadian Electrical Code, CSA C22.1, Parts I and II - (latest edition).

VENTILATION

The installation shall be made in such a manner as to separate the combustion system from the living space of the mobile home or recreational vehicle. Openings for air supply or for venting of combustion products shall have a minimum dimension of not less than 1/4 inch.

Proper installation requires one lower fresh air intake and one upper exhaust vent. The ventilation kits shown in this instruction manual have been certified for use with the refrigerator models listed in the Table. For *“Certified Vent System Kits”* see page 8.

The ventilation kits must be installed and used without modification. An opening toward the outside at floor level in the refrigerator compartment must be provided for ventilation of heavier-than-air fuel gases. The lower vent of the recommended kits is provided with proper size openings. The flow of combustion and ventilating air must not be obstructed.

The lower side vent is fitted with a panel, which provides an adequate access opening for ready serviceability of the burner and control manifold of the refrigerator. This should be centered on the back of the refrigerator.

CERTIFIED INSTALLATION

Certified installations require one roof vent and one lower side vent or optional one upper side vent and one lower side vent. For *“Certified Vent System Kits”* see page 8. For further information contact your dealer or distributor.

METHODS OF INSTALLATION

The method of installation is shown in FIG. 3a and 3b. It is essential that all maximum or minimum dimensions be strictly maintained, as the performance of the refrigerator is dependent on adequate flow of air over the rear of the refrigerator.

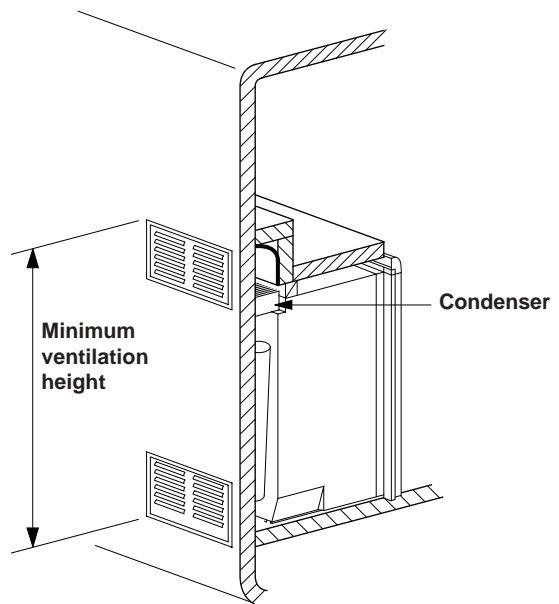

FIG. 3a

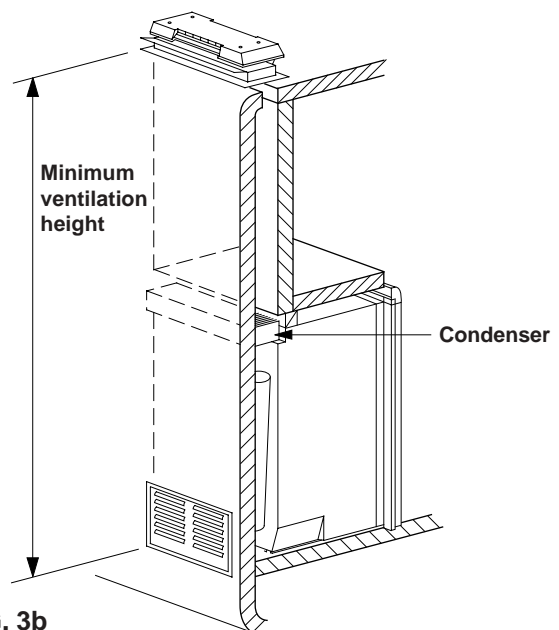
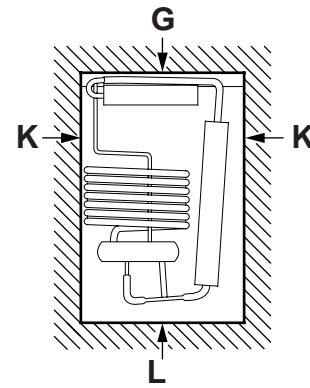

FIG. 3b

VENTILATION HEIGHTS

Refer to FIG. 3a, 3b and 4.

Refrigerator model	Minimum ventilation heights in inches and mm.	
	Installation with upper and lower side vent	Installation with roof vent and lower side vent
RM2351		
inch	34	31
mm	864	787



CLEARANCES

Minimum clearances in inches to combustible materials are:

- G: Top 0
- K: Side 0
- L: Bottom 0
- M: Rear 1
- N: See NOTE: "N" below.

NOTE: Clearance "M" is between the rearmost part of the refrigerator and the wall behind the refrigerator.

NOTE: Ventilation height "N"

With upper and lower side vent is "N" the distances between the bottom of the lower side vent to the top of the upper side vent.

With roof vent and lower side vent is "N" the distance between the bottom of the lower side vent to the roof material.

For ventilation height, see table **VENTILATION HEIGHTS**.

See Figures 3a, 3b and 4.

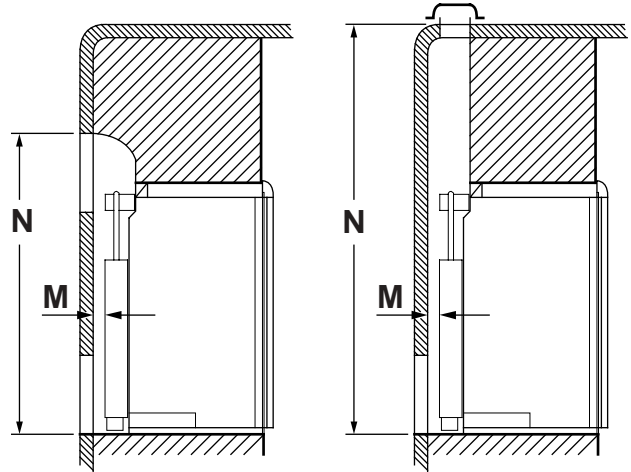
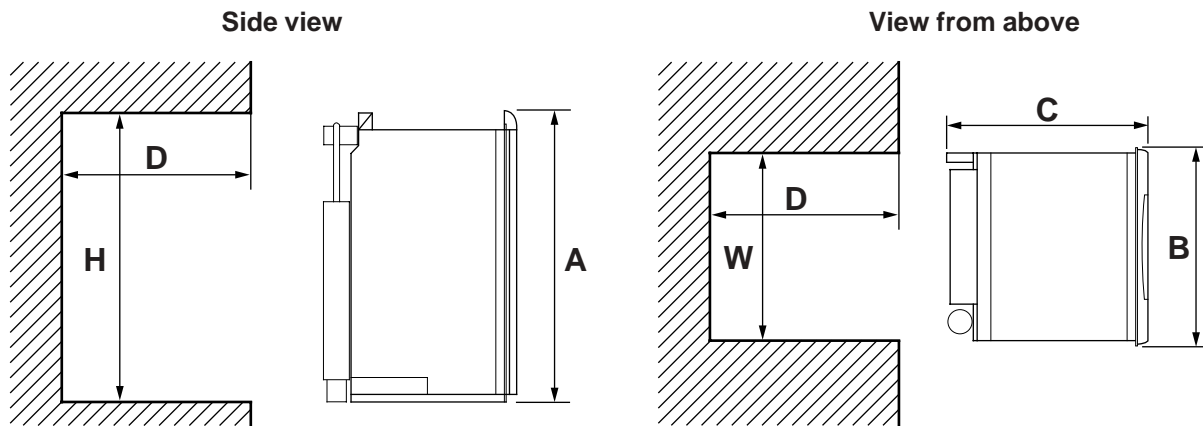

FIG. 4

FIG. 5



Refrigerator Model	Overall Dimensions			Recess Dimensions		
	Height A	Width B	Depth C	Height H	Width W	Depth D
RM2351 inch	30-5/32	21-7/8	22-23/32	29-3/4	20-1/2	21-3/8
mm	766	556	577	756	521	542

This method of installation and these clearances will give you adequate space for service and proper installation.

INSTALLING REFRIGERATOR IN ENCLOSURE

NOTE: DO NOT install the appliance directly on carpeting. Carpeting must be removed or protected by a metal or wood panel beneath the appliance, which extends at least full width and depth of the appliance.

The refrigerator must be installed in a substantial enclosure and must be level. When installing the refrigerator in the enclosure, all areas within the recess in which the refrigerator is installed must be sealed.

Make sure that there is a complete seal between the front frame of the refrigerator and the top, sides and bottom of the enclosure. A length of sealing strip is applied to the rear surface of the front frame for this purpose. Also apply a sealing strip to the foremost floor of the enclosure as shown in fig. 6. The sealing should provide a complete isolation of the appliance's combustion system from the vehicle interior.

NOTE: Be careful not to damage the sealing strip when the refrigerator is put in place.

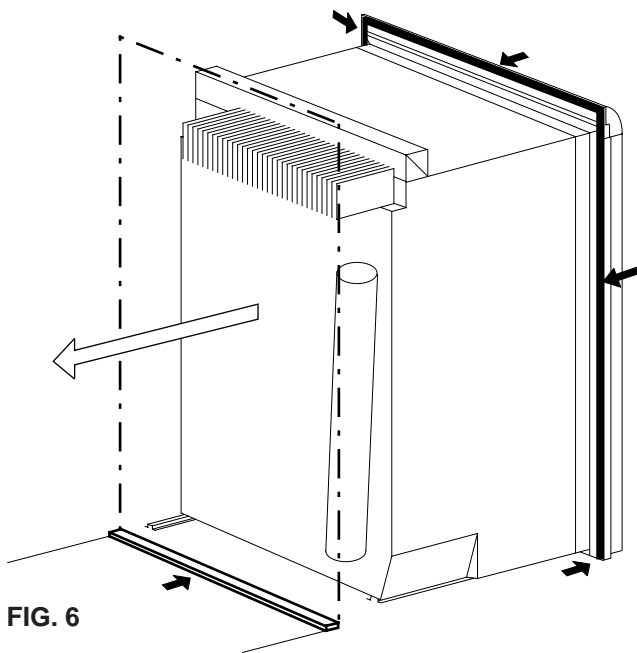

FIG. 6

Securing the Refrigerator

After the refrigerator is put in place, (insuring a combustion seal at the front frame), the refrigerator is to be secured in the enclosure with five screws (not included). The screws have to be installed in the following order:

STEP 1: Four screws installed through the front frame. See fig. 7.

STEP 2: One screw installed in rear base. See fig. 7.
In the parts bag there are plugs to be snapped in the front frame to cover the four screw heads.

Failure to follow the sequence in securing refrigerator in enclosure can cause leakage between the frame and cabinet.

When installing the refrigerator, the installer must block the space between the storage cabinet and the top of the refrigerator, otherwise heat will become trapped in this space, making the top of the refrigerator hot, thus reducing the efficiency of the unit.

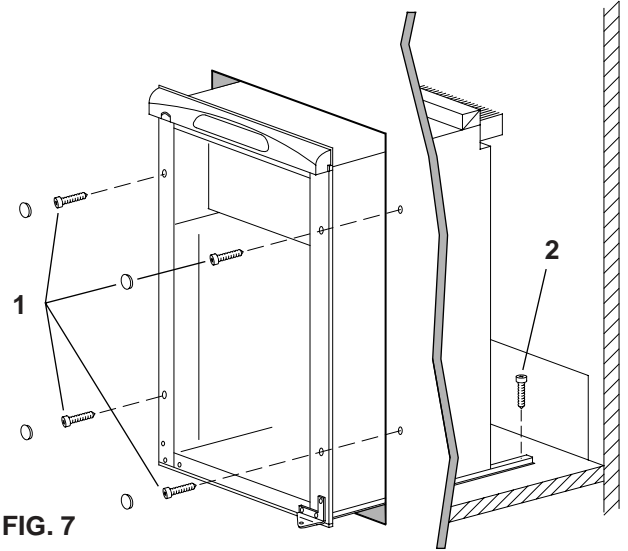

FIG. 7

Drain water hose

A hole must be drilled through flooring see FIG. 8. The installer MUST make sure that the hose does not kink when run through the floor. Seal around the hose that goes through the drilled hole. If a longer hose than supplied is required to get the water to drain outside of the vehicle, the installer will have to supply the extra length of hose.

GAS CONNECTION

Hook up to the gas supply line is accomplished at the manual gas valve, which is furnished with a 3/8" SAE (UNF 5/8" -18) male flare connection. All completed connections should be checked for leaks with soapy water.

! WARNING

DO NOT use a flame to check for gas leaks.

The gas supply system must incorporate a pressure regulator to maintain a supply pressure of not more than 11 inches water column.

When testing the gas supply system at test pressures in excess of 1/2 psi, the refrigerator and its individual shutoff valve must be disconnected from the gas supply piping system.

When testing the gas supply system at pressures less than or equal to 1/2 psi, the appliance must be isolated from the gas supply piping system by closing its individual manual shutoff valve.

In case detailed instructions on the installation and connection to the gas supply are required, contact your dealer or distributor.

TESTING LP GAS SAFETY SHUTOFF

The gas safety shutoff must be tested after the refrigerator is connected to the LP gas supply.

To test the gas safety shutoff, proceed as follows:

1. Start the refrigerator according to the instructions without connecting to 120 volts AC.
2. Check that the gas flame is lit. In AUTO mode the AUTO mode indicator lamp (A) is on.
3. Close the manual gas shutoff valve at the back of the refrigerator. (See FIG. 1).
4. Wait for one minute. The CHECK indicator lamp (B) should be on, and the flame extinguished.
5. Remove protection cover (see FIG. 1) and open the manual gas shutoff valve. Do not change any button position on the control panel. Apply a non-corrosive commercial bubble solution to the burner jet orifice.
6. No bubbles should appear at the opening of the burner jet orifice. The presence of bubbles indicates a defective gas safety shutoff, and service is required.
7. If no bubbles were present at the burner jet orifice, it should be rinsed with fresh water. Be careful not to damage the burner jet orifice. Replace cover and press the main power ON/OFF button (1) OFF and back ON. Normal operation of the burner should return. Allow the burner to operate for a minimum of 5 minutes.

ELECTRICAL CONNECTION

120 Volts AC Connection

The refrigerator is equipped with a three-prong (grounded) plug for protection against shock hazards and should be plugged directly into a properly grounded three-prong receptacle. DO NOT cut or remove the grounding prong from this plug. The free length of the cord is 2 feet. and therefore recommended that the receptacle be located to the left side of the refrigerator (viewed from the rear) and approximately 4-6 inches from the floor (see FIG. 8). This allows easy accessibility through the vent door. The cord should be routed to avoid contacting the burner cover, flue cover, or any other components that could damage the cord insulation.

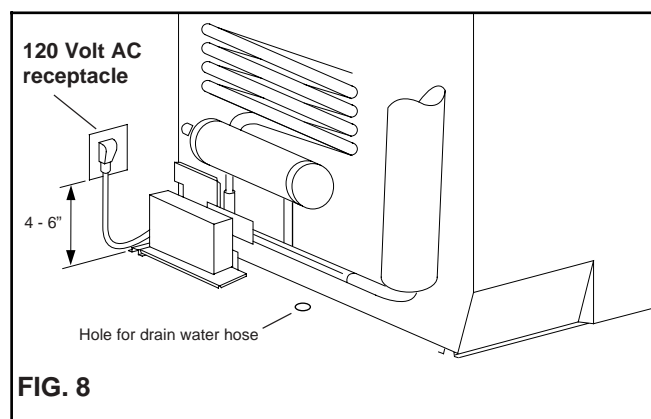

12 Volts DC Connection

This refrigerator model is not designed for 12 volt DC operation of the cooling system; however, 12 volt DC must be supplied to the refrigerator to operate the controls. Use a **minimum of 14 gauge wire** between the battery and refrigerator to supply the control voltage.

The connection is made to the positive (+) and negative (-) terminals of the terminal block on back of the refrigerator. (See FIG. 1). Correct polarity must be observed when connecting to the DC supply.

DO NOT use the chassis or vehicle frame as one of the conductors. Connect two wires at the refrigerator and route to the DC supply.

The distance the current must travel from the battery to the refrigerator dictates the AWG wire size to be used. Should the wire be too small for the distance, a voltage drop will result.

The connections must be clean, tight and free from corrosion.

CHANGING DOOR SWING TO OPPOSITE SIDE

A special Hinge Kit must be used to change door swing. For further information please contact The Dometic Corporation listed on the front page.

INSTRUCTIONS FOR MOUNTING THE DOOR PANEL

The refrigerator is normally delivered without door panel. The lower decoration strip and parts bag are taped inside the door.

Before starting the mounting work, check that the panel dimensions are in compliance with those given in the Table and the instructions are read thoroughly.

We recommend to mount the panel on the door before the refrigerator is installed in the enclosure.

When mounting the panel, proceed as follows:

- Slide the panel from the bottom of the door into the grooves on the vertical edges of the door .
- Push the panel upwards, take the two plastic panel stops from the parts bag and put them in the two holes at the lower door frame.
- Put the decoration strip across the door and fasten it with three screws from the parts bag.

PANEL DIMENSIONS					
MAX. THICKNESS 5/32" (4 mm)					
REFR. MODELS TYPE		HEIGHT		WIDTH	
		MAX.	MIN.	MAX.	MIN.
RM2351	inch mm	25-9/32 642	25-3/16 640	19-5/8 498	19-17/32 496

CERTIFIED VENT SYSTEM KITS

REFRIGERATOR MODEL	KIT NO.	COMPONENTS	PART NO.
RM2351	2A	Roof Base Roof Cover Lower Side Vent Lower Side Vent	3103633.XXX* 3103634.XXX* 3109350.XXX* RM183
	3A	Upper Side Vent Lower Side Vent	RM123A RM183
		Power Vent Asm. Upper Side Vent Upper Side Vent Lower Side Vent Lower Side Vent	3108705.751** RM123A 3109492.003 RM183 3109492.003
<p>* Fill in "XXX" with color code numbers. For color codes, contact your supplier. ** Alternate instructions forwarded with the Ventilator Kit.</p>			

For further information contact your dealer or distributor.

OPERATING INSTRUCTIONS

IMPORTANCE OF LEVELING A REFRIGERATOR

In an absorption refrigerator system, ammonia is liquefied in the finned condenser coil at the top rear of the refrigerator. The liquid ammonia then flows into the evaporator (inside the freezer section) and is exposed to a circulating flow of hydrogen gas, which causes the ammonia to evaporate, creating a cold condition in the freezer.

When starting this refrigerator for the very first time, the cooling cycle may require up to four hours of running time before the cooling unit is fully operational.

The tubing in the evaporator section is specifically sloped to provide a continuous movement of liquid ammonia, flowing downward by gravity through this section. If the refrigerator is operated when it is not level and the vehicle is not moving, liquid ammonia will accumulate in sections of the evaporator tubing. This will slow the circulation of hydrogen and ammonia gas, or in severe cases, completely block it, resulting in a loss of cooling.

Any time the vehicle is parked for several hours with the refrigerator operating, the vehicle should be leveled to prevent this loss of cooling.

The vehicle needs to be leveled only so it is comfortable to live in (no noticeable sloping of floor or walls).

When the vehicle is moving, the leveling is not critical, as the rolling and pitching movement of the vehicle will pass to either side of level, keeping the liquid ammonia from accumulating in the evaporator tubing.

OPERATION

Before starting the refrigerator, check that all the manual gas valves are in the ON position. DO NOT forget the manual shutoff valve on the rear of the refrigerator see FIG. 1.

This refrigerator is equipped with a control system, which can be set to automatically select either 120 Volt AC or LP gas operation (AUTO mode), or if desired LP gas only (GAS mode).

In both AUTO mode and GAS mode operation, the temperature is controlled by a factory preset temperature setting.

The refrigerator controls will work down to 9.6 volt DC.

! WARNING

Most LP gas appliances used in recreational vehicles are vented to the outside of the vehicle. When parked close to a gasoline pump, it is possible that the gasoline fumes could enter this type of appliance and ignite from the burner flame, CAUSING A FIRE OR AN EXPLOSION.

FOR YOUR SAFETY, when refueling, shut off all LP gas appliances which are vented to the outside.

Refrigerator control panel

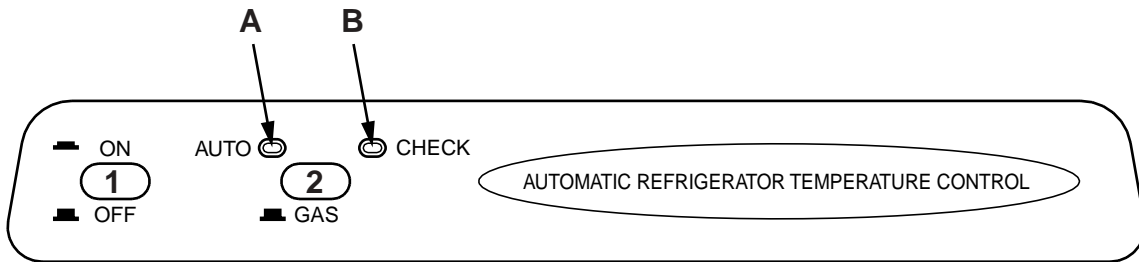

START UP INSTRUCTIONS

- A. A continuous 12 volt DC supply must be available for the electronic control to function.
- B. Press the main power ON/OFF button (1) to the DOWN position.
- C. In AUTO mode operation, the temperature is controlled by a factory preset temperature setting, on the energy source selected by the control system.
- D. In GAS mode operation, the temperature is controlled by a factory preset temperature setting.

AUTO MODE

1. Press the AUTO/GAS mode selector button (2) to the DOWN position. The AUTO mode indicator lamp (A) will illuminate. If 120 volts AC is available, the control system will select AC operation. If 120 volts AC is not available, the control system will automatically switch to GAS operation. Within 45 seconds the burner should be ignited and operating normally.
2. If the CHECK indicator lamp (B) illuminates, the control has failed to ignite the burner on GAS.
To reset when the CHECK indicator lamp (B) is illuminated, press the main power ON/OFF button (1) to the OFF then ON position.
3. On the initial refrigerator start-up on gas (120 volts AC is not available), it may take longer than 45 seconds to allow air to be purged from the gas line.
If the refrigerator has not been used for a long time or the LP tanks have just been refilled, air may be trapped in the supply lines. To purge the air from the lines may require resetting the main power ON/OFF button (1) three or four times. If repeated attempts fail to start the LP gas operation, check to make sure that the LP gas supply tanks are not empty and all manual shutoff valves in the lines are open. If the problem is still not corrected, contact a service center for assistance.
NOTE: Do not continue to reset GAS operation if the CHECK indicator lamp continues to be illuminated after several tries.
4. In AUTO mode operation, the temperature is controlled by a factory preset temperature setting.

GAS MODE

1. Move the AUTO/GAS mode selector button (2) to the UP position. The AUTO mode indicator lamp (A) will go off. Within 45 seconds the burner should be ignited and operating normally.
2. If the CHECK indicator lamp (B) illuminates, the control has failed to ignite the burner on GAS.
To reset when the CHECK indicator lamp (B) is illuminated, press the main power ON/OFF button (1) to the OFF then ON position.
3. On the initial refrigerator start-up on gas, it may take longer than 45 seconds to allow air to be purged from the gas line. If the refrigerator has not been used for a long time or the LP tanks have been refilled, air may be trapped in the supply lines. To purge the air from the lines may require resetting the main power ON/OFF button (1) three or four times. If repeated attempts fail to start the LP gas operation, check to make sure that the LP gas supply tanks are not empty and all manual shutoff valves in the lines are open. If the problem is still not corrected, contact a service center for assistance.
NOTE: Do not continue to reset GAS operation if the CHECK indicator lamp continues to be illuminated after several tries.
4. In GAS mode operation, the temperature is controlled by a factory preset temperature setting.

TO SHUT OFF THE REFRIGERATOR

The refrigerator may be shut off while in any mode of operation by pressing the main power ON/OFF button to the UP (OFF) position. This shuts off all DC power to the control system.

Refrigerator control panel

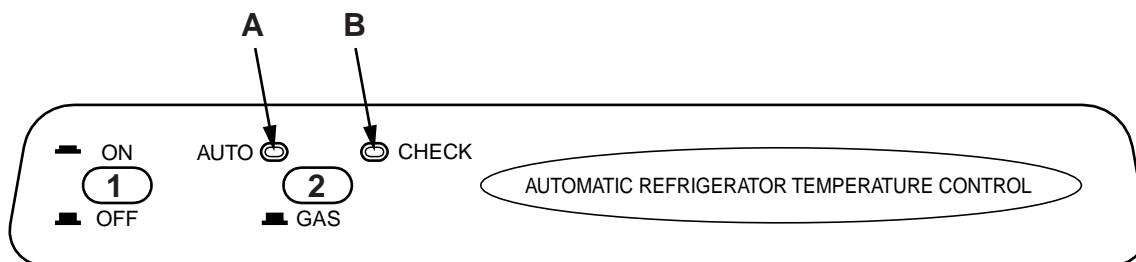

DESCRIPTION OF OPERATING MODES

AUTO MODE

When operating in the AUTO mode, the AUTO mode indicator lamp (A) will illuminate.

The control system will automatically select between AC and GAS operation with AC having priority over GAS. If the control system is operating with AC energy and it then becomes unavailable, the system will automatically switch to GAS. As soon as AC becomes available again the control will switch back to AC operation.

Gas operation (120 volts AC is not available). The control system will activate the ignition system and will make three attempt to light the burner for a period of approximately 45 seconds with two minutes interval. If unsuccessful, the CHECK indicator lamp (B) will illuminate.

To restart an ignition attempt with the CHECK lamp illuminated or to clear (turn off) the CHECK lamp, press the main power ON/OFF button to the OFF and then ON position. The control system will attempt a new ignition sequence.

If 120 volts AC becomes available while the CHECK indicator lamp is on, the CHECK lamp will not turn off until the main power ON/OFF button is pressed to the OFF then ON position.

GAS MODE

When operating in the GAS mode, the AUTO mode indicator lamp (A) will be off. This mode provides LP gas operation only. The control system will activate the ignition system and will make three attempt to light the burner for a period of approximately 45 seconds with two minutes interval. If unsuccessful, the CHECK indicator lamp (B) will illuminate.

To restart GAS operation, press the main power ON/OFF button (1) to the OFF and then ON position. The control system will attempt a new ignition sequence.

If the refrigerator has not been used for a long time or the LP tanks have just been refilled, air may be trapped in the supply lines. To purge the air from the lines may require resetting the main power ON/OFF button (1) three or four times. If repeated attempts fail to start the LP gas operation, check to make sure that the LP gas supply tanks are not empty and all manual shutoff valves in the lines are open. If the problem is still not corrected, contact a service center for assistance.

LIMP MODE OF OPERATION

This control system contains a feature where it will continue to operate the cooling system in event of a failure of a major operating component.

If the control cannot read the temperature sensor and control to the preset temperature, then the control will run the cooling unit continuously at the energy source available.

The refrigerator will continue to operate in this mode indefinitely or until a new sensor is installed and the system is reset.

HOW TO USE THE REFRIGERATOR

FOOD STORAGE COMPARTMENT

The food storage compartment is completely closed and unventilated, which is necessary to maintain the required low temperature for food storage. Consequently, foods having a strong odor or those that absorb odors easily should be covered. Vegetables, salads etc. should be covered to retain their crispness. The coldest positions in the refrigerator are under the cooling fins and at the bottom of the refrigerator. The warmer areas are on the upper door shelves. This should be considered when placing different types of food in the refrigerator.

FROZEN FOOD STORAGE COMPARTMENT

Quick frozen soft fruits and ice cream should be placed in the coldest part of the compartment, which is at the bottom of the aluminum liner. Frozen vegetables, may be stored in any part of the compartment.

This compartment is not designed for deep or quick-freezing of food. Meat or fish, whether raw or prepared, can be stored in the frozen food storage compartment provided they are precooled first in the refrigerator. They can be stored about three times longer in the frozen food compartment as compared to the fresh food compartment. To prevent food from drying out, keep it in covered dishes, containers, plastic bags or wrapped in aluminum foil.

Ice cubes can be made in the freezer compartment. For faster ice making, the tray should be placed in direct contact with the bottom of the freezer compartment.

Total Refrigerated Volume 3 cu.ft.

DEFROSTING

Shut off the refrigerator by pressing the main power ON/OFF button to the UP (OFF) position. Empty the refrigerator, leaving the drip tray under the finned evaporator, and the cabinet and freezer doors open. Defrosting time can be reduced by filling the ice trays with hot water and placing them in the freezer compartment.

! CAUTION

DO NOT use a hot air blower. Permanent damage could result from warping the metal or plastic parts. DO NOT use a knife or an ice pick, or other sharp tools to remove frost from the freezer compartment. They can create a leak in the ammonia system.

When all the frost has melted, dry the interior of the refrigerator with a clean cloth. Replace all food and turn your refrigerator back on.

CLEANING THE REFRIGERATOR

Cleaning the refrigerator is usually done after it is defrosted or put into storage. To clean the interior liner of the refrigerator, use lukewarm weak soda solution. Use only warm water to clean the finned evaporator, gasket, ice tray and shelves.

NEVER use strong chemicals or abrasives to clean these parts, as the protective surfaces will be damaged. It is important to always keep the refrigerator clean.

SHUT- OFF (STORAGE PROCEDURE)

Shut off the refrigerator by pressing the main power ON/OFF button to the UP (OFF) position.

If the refrigerator will not be in operation for a period of weeks, it should be emptied, defrosted, cleaned and the doors left ajar. The ice trays should also be dried and kept outside the cabinet.

! WARNING

DO NOT store explosive substances in the refrigerator, such as cigarette lighter gas, gasoline, ether or the like.

NOTE: Sodium chromate is used for corrosion protection (less than 2 weight % of the coolant).

MAINTENANCE & SERVICE

The user should be aware of service that must be done on a regular schedule to keep the refrigerator operating properly. The service should only be performed by a qualified technician who is familiar with LP gas systems and refrigerators.

1. HEATER

The heat necessary for the operation of an absorption cooling unit is supplied by an electric heater mounted in a pocket of the boiler system. This model is equipped with one electric heater for 120 volt AC.

To replace the heater proceed as follows:

1. Unplug the refrigerator power cord from the 120-volt AC outlet.
2. Disconnect or shut off the 12 volt DC power to the refrigerator.
3. Remove the power module cover see FIG. 1.
4. Disconnect the heater leads.
5. With a pair of pliers unfold the lug holding the lid of the boiler casing and open the lid.
6. Remove some insulation wool so that the heater is accessible.
7. Turn and lift the heater out of its pocket.
8. Fit the new heater into the pocket.
9. Connect the heater leads and put on the power module cover.
10. Reset the insulation and close the lid of the boiler.

2. REFRIGERATOR REMOVAL

Before working on the refrigerator, make sure the AC voltage and DC voltage leads are disconnected. Shut off the gas supply at the LP tank. Disconnect the gas supply line at the rear of the refrigerator, see FIG. 1. Always use a back up wrench when loosening and tightening connections.

Cap the gas supply line, loosen the screws anchoring the refrigerator to the enclosure and slide the refrigerator out of the compartment.

When replacing the refrigerator make sure that the sealing strips are properly positioned.

Replacement is the reverse of removal. Check all connections for gas leaks.

Refer to section **INSTALLATION**, page 4 to 8.

3. PERIODIC MAINTENANCE

To keep your Dometic refrigerator operating efficiently and safely, periodic inspection and cleaning of several components once or twice a year is recommended.

- A. It is important to keep the area at the back of the refrigerator clean. Check the lower vent, upper vent and area between these openings for any obstructions such as bird/insect nests, spider webs, etc. Clean the coils on the back of the refrigerator. Use a soft bristled brush to dust off the coils.

It is important to keep the refrigerator area free from combustible material, gasoline and other flammable vapors or liquids.

NOTE: The following maintenance is required once or twice a year, but should only be done by a qualified serviceman who is familiar with LP gas systems and refrigerators.

- B. Check all connections in the LP gas system (at the back of the refrigerator) for gas leaks. The LP gas supply must be turned on. Apply a non-corrosive bubble solution to all LP gas connections.

The appearance of bubbles indicates a leak and should be repaired **immediately** by a QUALIFIED SERVICEMAN WHO IS FAMILIAR WITH GAS SYSTEM AND REFRIGERATORS.

! WARNING

DO NOT use a flame to check for gas leaks.

GAS EQUIPMENT ASSEMBLY

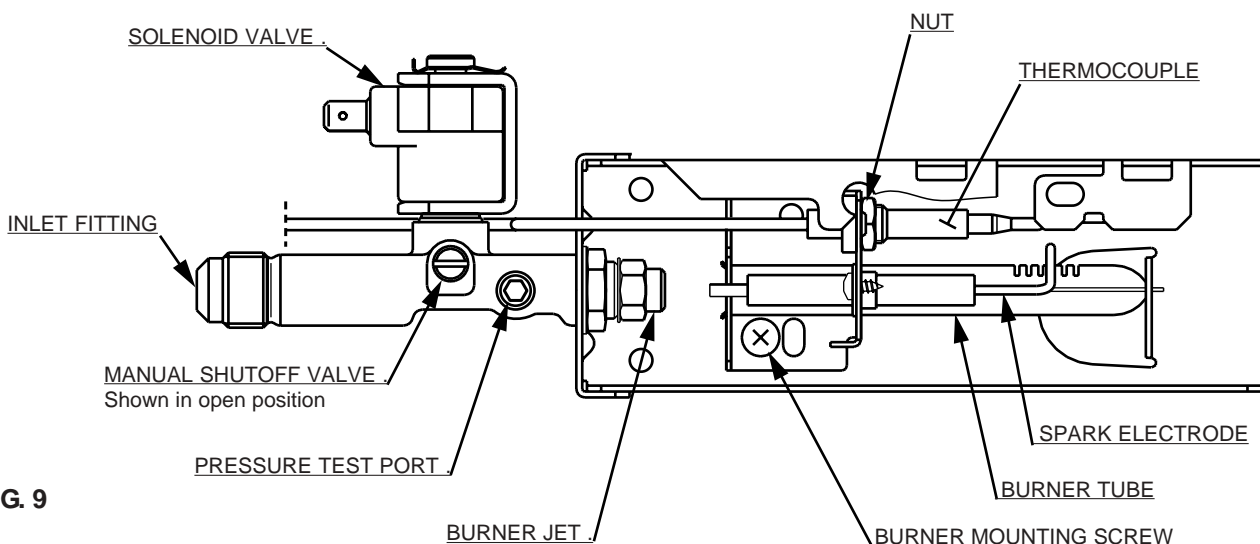
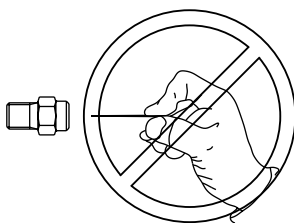

FIG. 9

- C. Check the control system by connecting/disconnecting 120 volt AC power, start/stop the engine, etc. Compare the operation with the operation described in section Operating Instructions.
- D. The LP gas pressure should be checked and the main regulator readjusted if pressure is incorrect. The correct operating pressure is 11 inches of water column. The correct place to take the LP gas pressure is at the test port just ahead of the burner jet. (See FIG. 9).
- E. Inspect the flue baffle. It should be reasonably clean and free of soot. Heavy soot formation indicates improper functioning of the burner. The flue and burner both require cleaning in the following manner:
1. Unplug the refrigerator power cord from the 120-volt AC outlet. (See FIG. 8).
 2. Disconnect or shut off the 12 volt DC power to the refrigerator.
 3. Turn manual shutoff valve to OFF. (See FIG. 1 & 9).
 4. Remove cover from the burner housing. (See fig. 1).
 5. Disconnect the wire from the high voltage electrode.
 6. Remove the burner mounting screw and remove the burner assembly. (See FIG. 9).
 7. Remove the wire and flue baffle from the top of flue tube. Clean the flue from the top using a flue brush. Blowing compressed air into the flue **will not** properly clean soot and scale out of the flue tube. Replace the flue baffle.
 8. Clean burner tube with a brush. Blow out burner with compressed air.
 9. Before removing burner jet, clean burner area of soot and scale that fell out of flue tube. Remove the burner jet. Soak the jet in wood alcohol and blow it out with compressed air. Reinstall and tighten burner jet.

! WARNING

DO NOT use a wire or pin when cleaning the burner jet as damage can occur to the precision opening. This can cause damage to the refrigerator or create a fire hazard.



10. Reinstall burner, being careful that the end of the burner fits into the slot on the burner bracket. Check to make sure slots are centered under the flue tube and the thermocouple is positioned properly (tip of thermocouple extends over two slots of burner).

NOTE: The color of the flame shall be clear blue over the slots of the burner. (See FIG. 10).

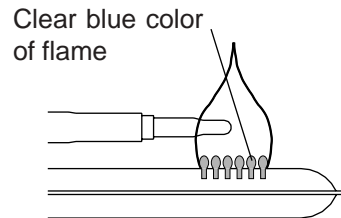
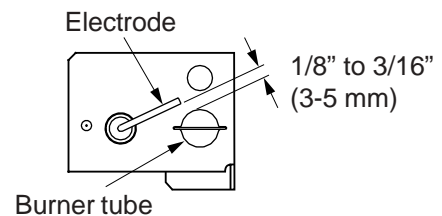

FIG. 10

11. Be sure to reconnect the wire to high voltage electrode. Check the electrode for proper location and gap. (See FIG. 11).

FIG. 11



12. Turn on manual gas shutoff valve and check all fittings for leaks with soapy water.
13. Connect 120-volt power cord to the outlet and reconnect or turn on the 12-volt DC power.
14. Check LP gas safety shutoff. See page 7.

F. FUSES

The refrigerator is equipped with 2 fuses, one for the refrigerator control system, and one for the AC cartridge heater (see table below).

To replace fuse(s) proceed as follows.

1. Disconnect the wall plug, and the 12 volt wires.
2. Remove the power module cover. See FIG. 1.
3. Snap the fuse out of the fuse holder.
4. Fit a new fuse in to the fuse holder.
5. Replace the power module cover.

Control system	3 Amp
AC heater	5 Amp

4. TROUBLESHOOTING

Refrigerator Does Not Cool Properly

- A. Burner jet clogged.
Clean. (See section Maintenance & Service, Item 3. Periodic Maintenance, Paragraph E. Item 1-14).
- B. Check level of refrigerator.
- C. Venting problem.
Restriction in air flow across cooling unit.
- D. Heavy frost buildup on evaporator fins.
Defrost
- E. Flue baffle not inserted properly in flue tube.
- F. Burner dirty.
Clean. (See section Maintenance & Service, Item 3. Periodic Maintenance, Paragraph E. Item 1-14).

- G. LP gas pressure low at burner.
Set main regulator so pressure does not drop below 11 inches of water column at pressure test port (See FIG. 9).
- H. Burner not located properly under flue tube.
Relocate
- I. Burner damaged.
Replace
- J. Odor from fumes.
 - 1. Dislocated burner
 - 2. Damaged burner
 - 3. Dirty flue tube
- K. FUSES
 - 1. Refrigerator control system
 - 2. Refrigerator AC Supply
 See section Maintenance & Service, item 3. Periodic Maintenance, Paragraph F.

NOTE: AVOID SPRAYING WATER THROUGH THE REFRIGERATOR VENTS WHILE WASHING YOUR RV.

All the above instructions are to be followed closely. The refrigerator is quality-guaranteed. However, we are not responsible for any failures caused by improper adjustments and unfavorable installation conditions. Contact service point or distributor service dept. for assistance.

SPARE PARTS

The following list is a list of commonly used parts, which should be available, if required, from your Dometic Service Center.

Part No.	Description
17 37 71-02/3	Heater, 175W, 120V
200 22 61-24/2	Door shelf, 3 pieces
200 71 72-02/2	Baffle
200 74 19-15/9	Jet, No.39
293 27 81-01/2	Electrode
293 06 97-07/9	Burner
293 20 52-01/8	Thermocouple
293 26 36-01/8	Box
293 11 32-02/7	Spark ignition device

Hinge Kit from right to left and left to right
385 03 04-01/9 (light brown)

Hinge Kit from right to left and left to right
385 03 04-02/7 (black)

Contact an authorized service center for parts and repairs as needed

Removing and replacing of shelves (General)

The number of shelves and position may vary between refrigerator models.

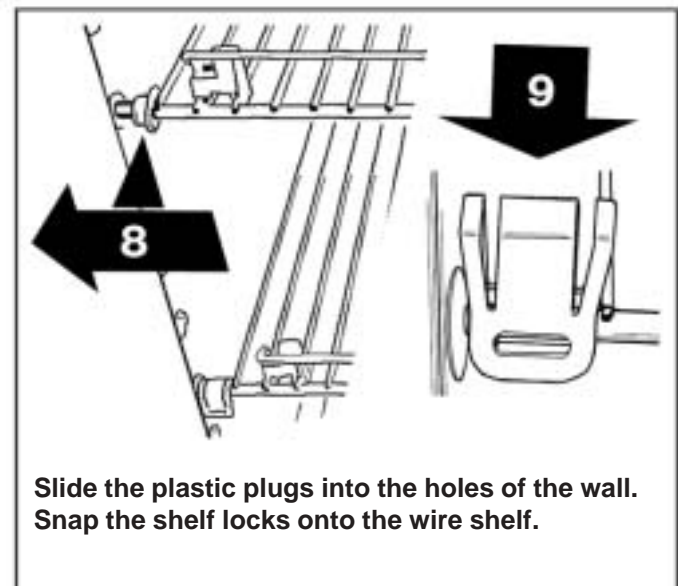
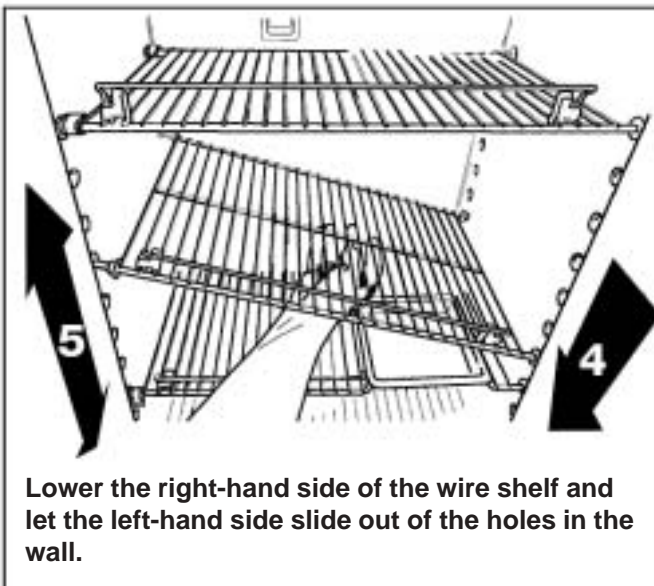
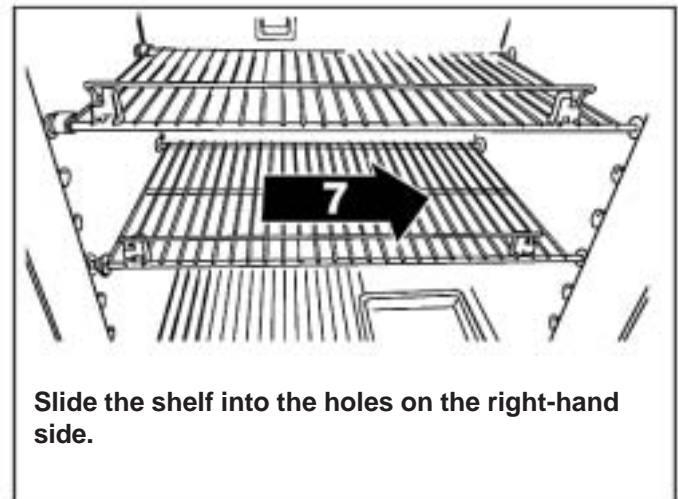
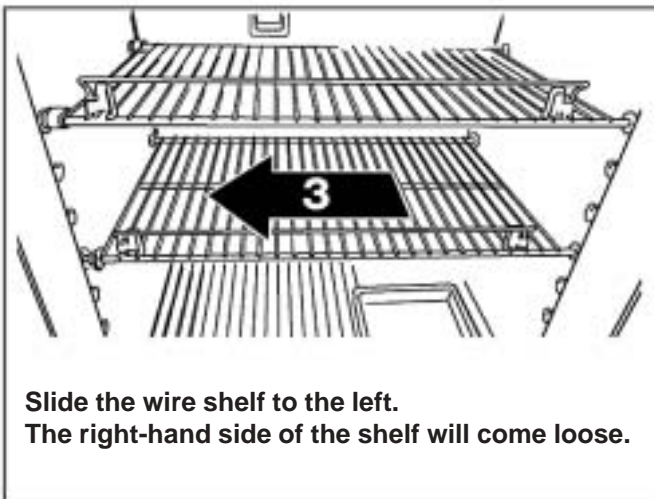
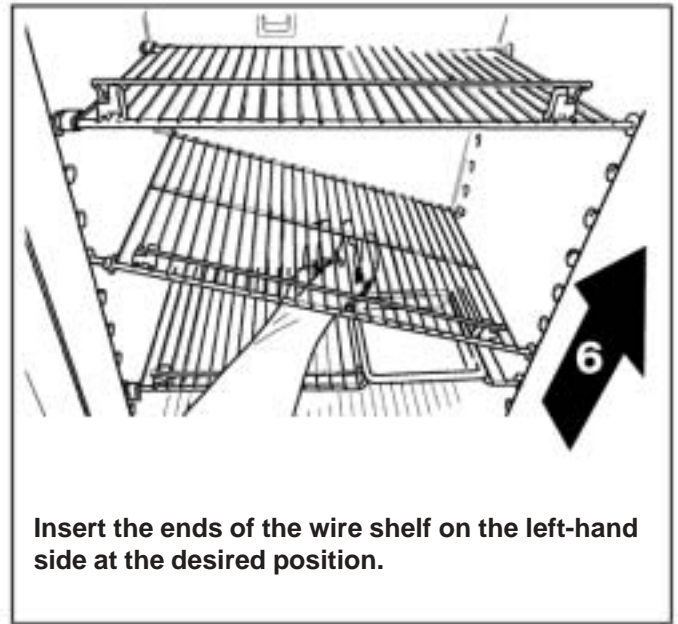
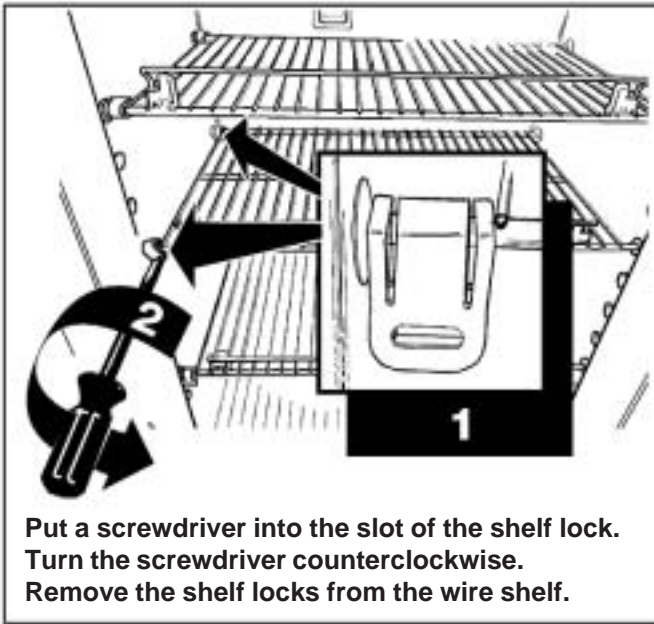

RM2351

